

60 SERIES

CAPACITY: 150 — 400 LBS PER CASTER



16-65-XD

FEATURES

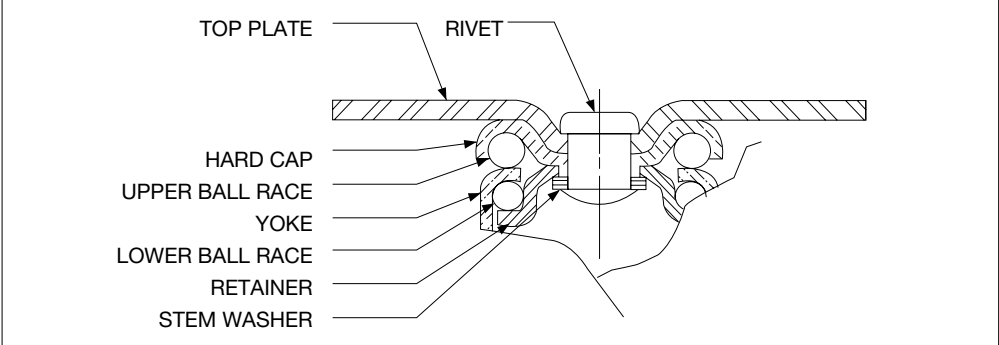

16-65R-XD

- 3/8" Axle
- 1/2" Rivet
- Double row ball bearing swivel. Both raceways equal diameter
- Bright zinc finish
- All swivel parts case hardened to Rockwell 62C
- Thread guards standard on wheels

OPTIONS

- Brakes available, 3", 3.5", 4", and 5" models. Add letter "B".
- Four position swivel locks. Add letter "F". Not available on stem casters.
- Brakes and swivel locks cannot be combined on the same caster.
- Swivel seals with zerk in swivel and axle. Add letter "S".
- Zerk in axle only. Add letter "G".



16-65B-XSR

INSTALLATIONS

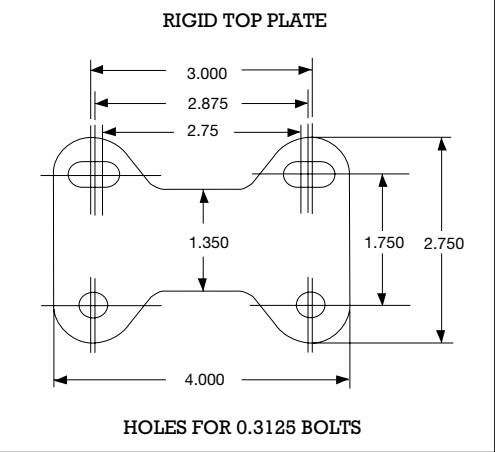
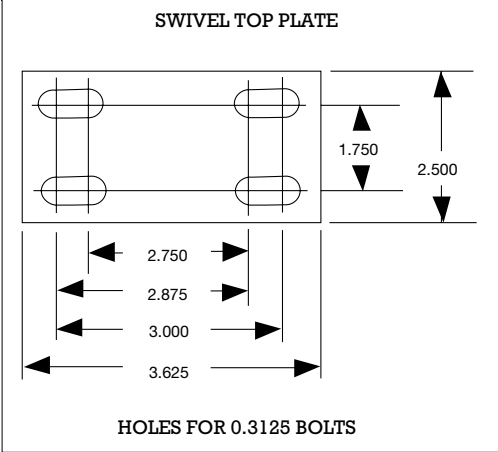

NO. 16 TOP PLATE (STANDARD ON 60 SERIES)

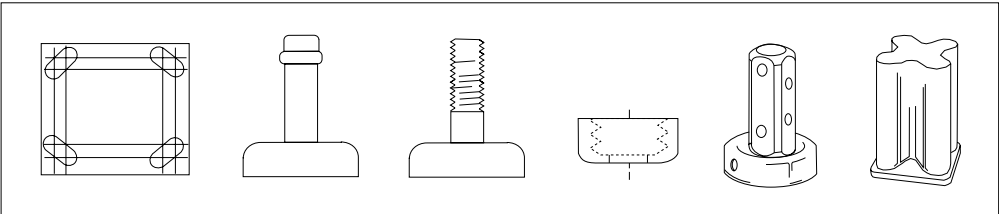

OPTIONAL TOP PLATES AND STEMS ARE AVAILABLE. SEE PAGES 14, 15, 16.

60 SERIES

CAPACITY: 150 – 400 LBS PER CASTER

WHEEL DIAMETER	TREAD WIDTH	LOAD CAP./LBS	BEARING TYPE	SWIVEL MODEL	RIGID MODEL	SWIVEL RADIUS	OVERALL HEIGHT
NEOPRENE - NON MARKING AND NON STAINING - USED ON ANY FLOOR SURFACE - ERGO*							
3"	1-3/8"	200	BALL	16-63-XD	16-63R-XD	2-3/4"	4-5/16"
3-1/2"	1-3/8"	200	BALL	16-63.5-XD	16-63.5R-XD	3"	4-3/4"
4"	1-3/8"	225	BALL	16-64-XD	16-64R-XD	3-1/4"	5-5/16"
5"	1-3/8"	250	BALL	16-65-XD	16-65R-XD	4"	6-5/16"
NEOPRENE - SUPER ROLL SOFT LOW PROFILE TREAD FOR EXTREMELY EASY ROLLING AND SWIVELING - ERGO*							
2-1/2"	1-3/8"	200	BALL	16-62.5-XSR	16-62.5R-XSR	2-1/2"	3-13/16"
3-1/2"	1-3/8"	225	BALL	16-63.5-XSR	16-63.5R-XSR	3"	4-3/4"
4"	1-3/8"	275	BALL	16-64-XSR	16-64R-XSR	3-1/4"	5-5/16"
5"	1-3/8"	325	BALL	16-65-XSR	16-65R-XSR	4"	6-5/16"
SOLID ELASTOMER-VERY LOW STARTING AND ROLLING RESISTANCE - ERGO*							
2-1/2"	1-1/4"	300	BALL	16-62.5-XSE	16-62.5R-XSE	2-1/2"	3-13/16"
3-1/2"	1-1/4"	350	BALL	16-63.5-XSE	16-63.5R-XSE	3"	4-3/4"
SEMI-STEEL - CROWNED SEMI-STEEL CASTING							
2-1/2"	1-1/4"	400	SLEEVE	16-62.5-CI	16-62.5R-CI	2-1/2"	3-13/16"
3"	1-3/8"	400	SLEEVE	16-63-CI	16-63R-CI	2-3/4"	4-5/16"
3-1/2"	1-1/4"	400	SLEEVE	16-63.5-CI	16-63.5R-CI	3"	4-3/4"
4"	1-3/8"	400	SLEEVE	16-64-CI	16-64R-CI	3-1/4"	5-5/16"
5"	1-3/8"	400	SLEEVE	16-65-CI	16-65R-CI	4"	6-5/16"
V-GROOVED - ECONOMICAL HANDLING OF HEAVY LOADS ON ANGLE TRACK							
3"	1-1/4"	300	SLEEVE	16-63-CV	16-63R-CV	2-3/4"	4-5/16"
RUBBER - SEMI-RESILIENT RUBBER MATERIAL							
3-1/2"	1-3/8"	150	SLEEVE	16-63.5-K	16-63.5R-K	3"	4-3/4"
4"	1-3/8"	175	SLEEVE	16-64-K	16-64R-K	3-1/4"	5-5/16"
5"	1-3/8"	175	SLEEVE	16-65-K	16-65R-K	4"	6-5/16"
HARD RUBBER - HARD SYNTHETIC RUBBER MATERIAL NOT AFFECTED BY OIL OR GREASE							
3"	1-3/8"	350	SLEEVE	16-63-H	16-63R-H	2-3/4"	4-5/16"
3-1/2"	1-3/8"	375	SLEEVE	16-63.5-H	16-63.5R-H	3"	4-3/4"
4"	1-3/8"	400	SLEEVE	16-64-H	16-64R-H	3-1/4"	5-5/16"
5"	1-3/8"	400	SLEEVE	16-65-H	16-65R-H	4"	6-5/16"

* Ergonomically designed for easy rolling.

SLEEVE - M - BEARINGS AVAILABLE FOR WET APPLICATIONS.